

2 WT.

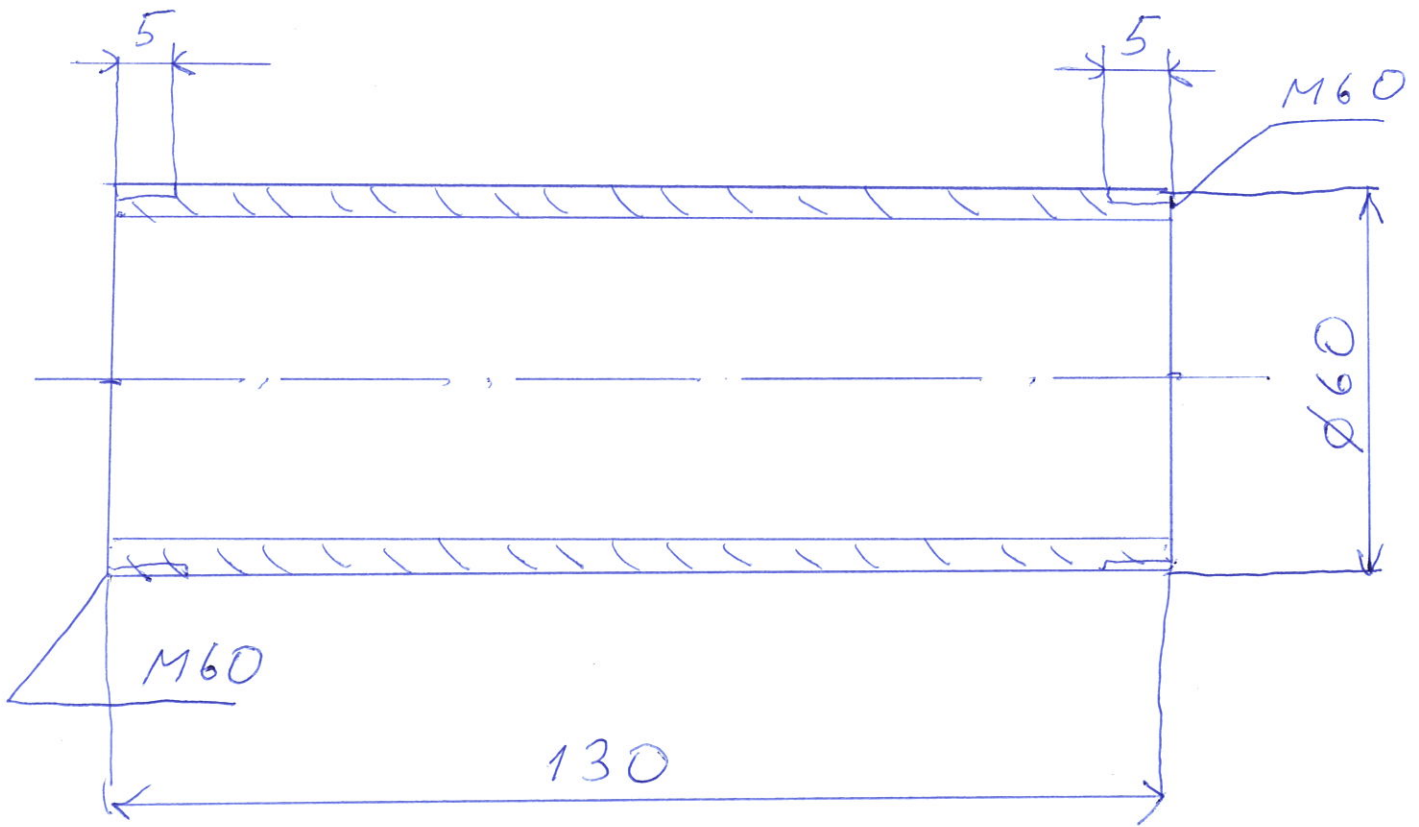

4 WT

