

$\sqrt{10} (\checkmark)$

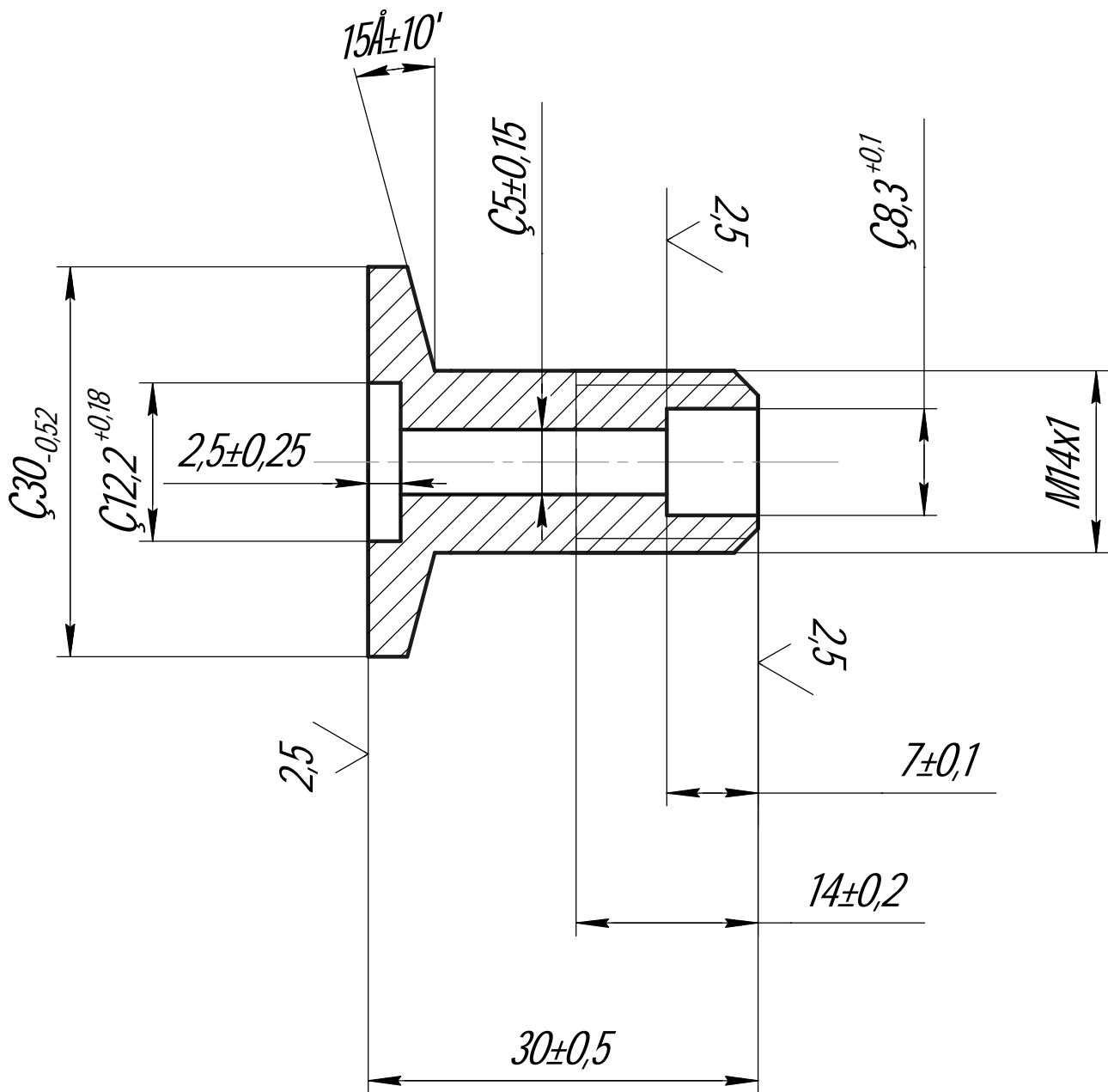

12 18 10

2:1

1

$\sqrt{10} (\checkmark)$

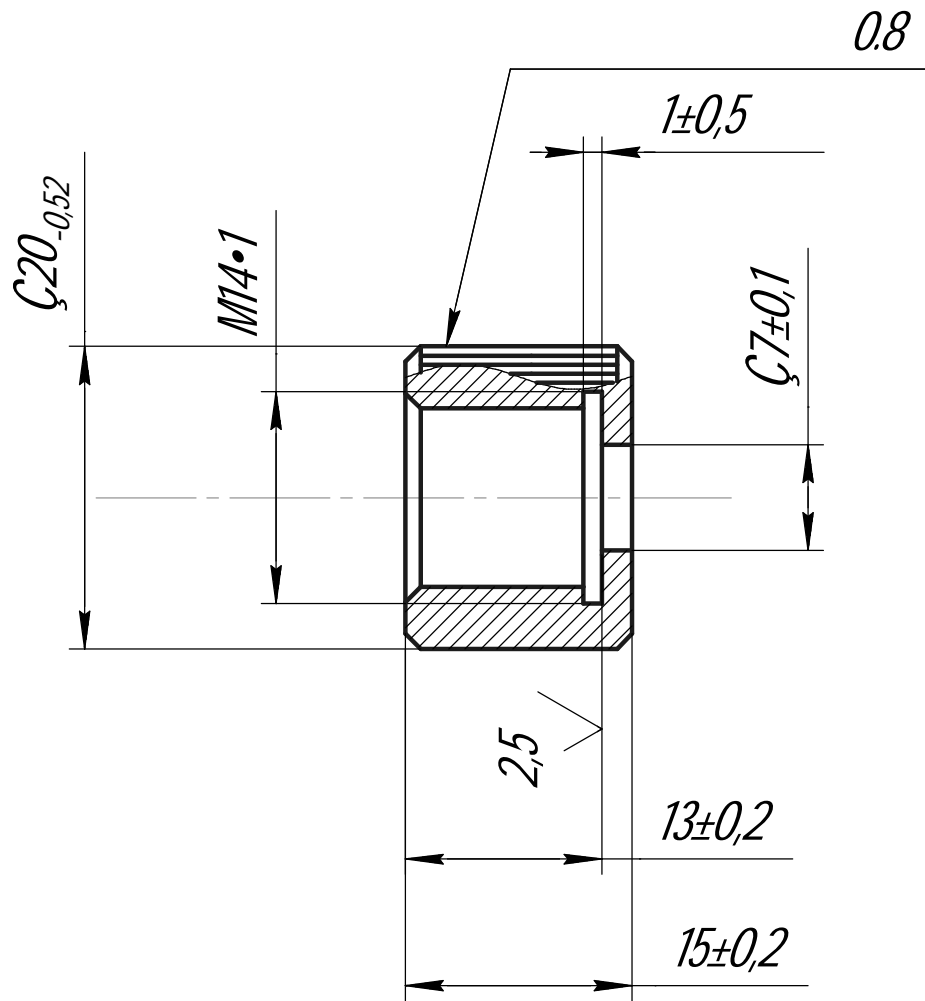

- 1. -
- 2. -
- 3. - 1 45

2:1

1

12 18 10

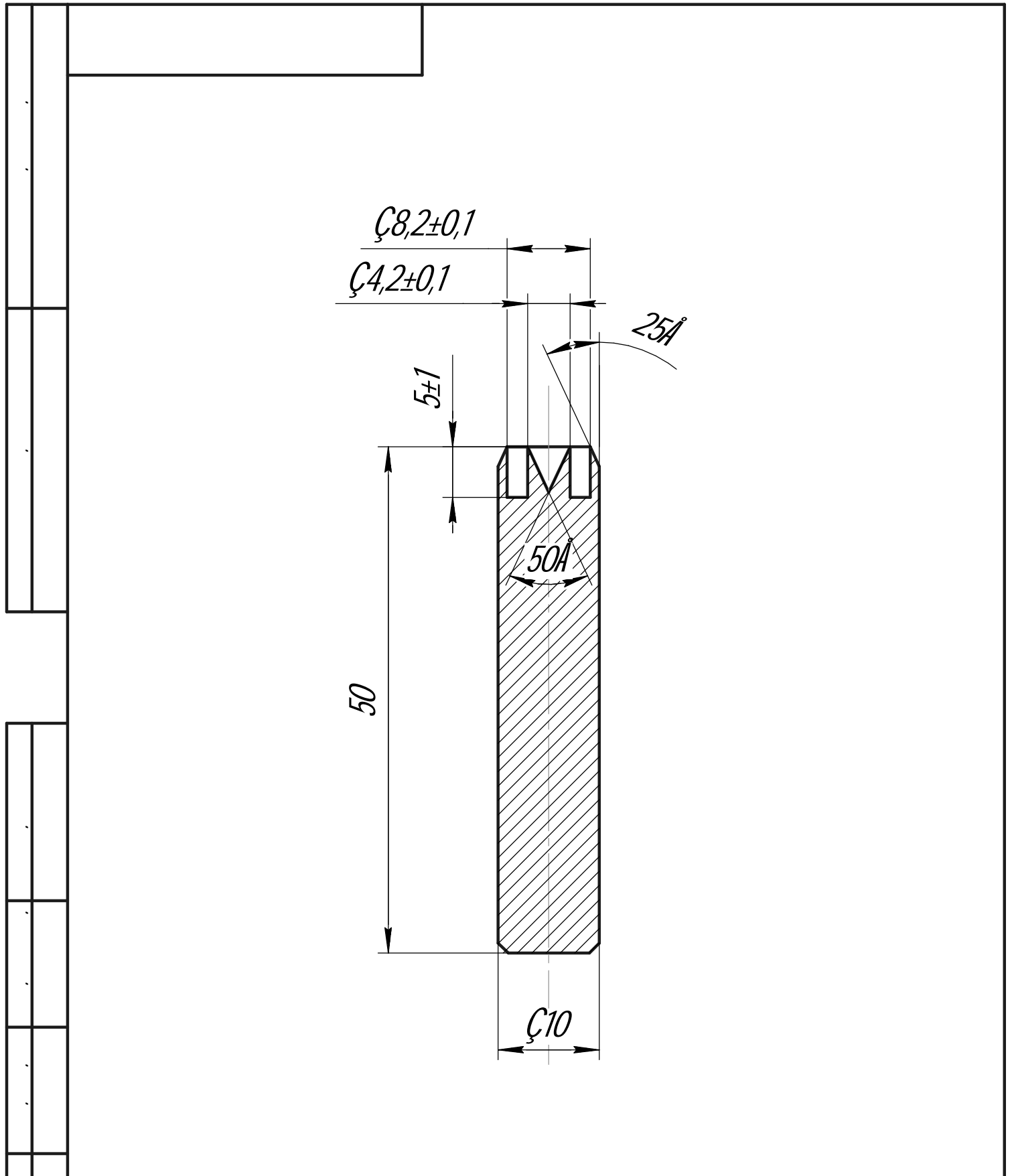

		$2:1$	
		1	
10			