

Ножки стола

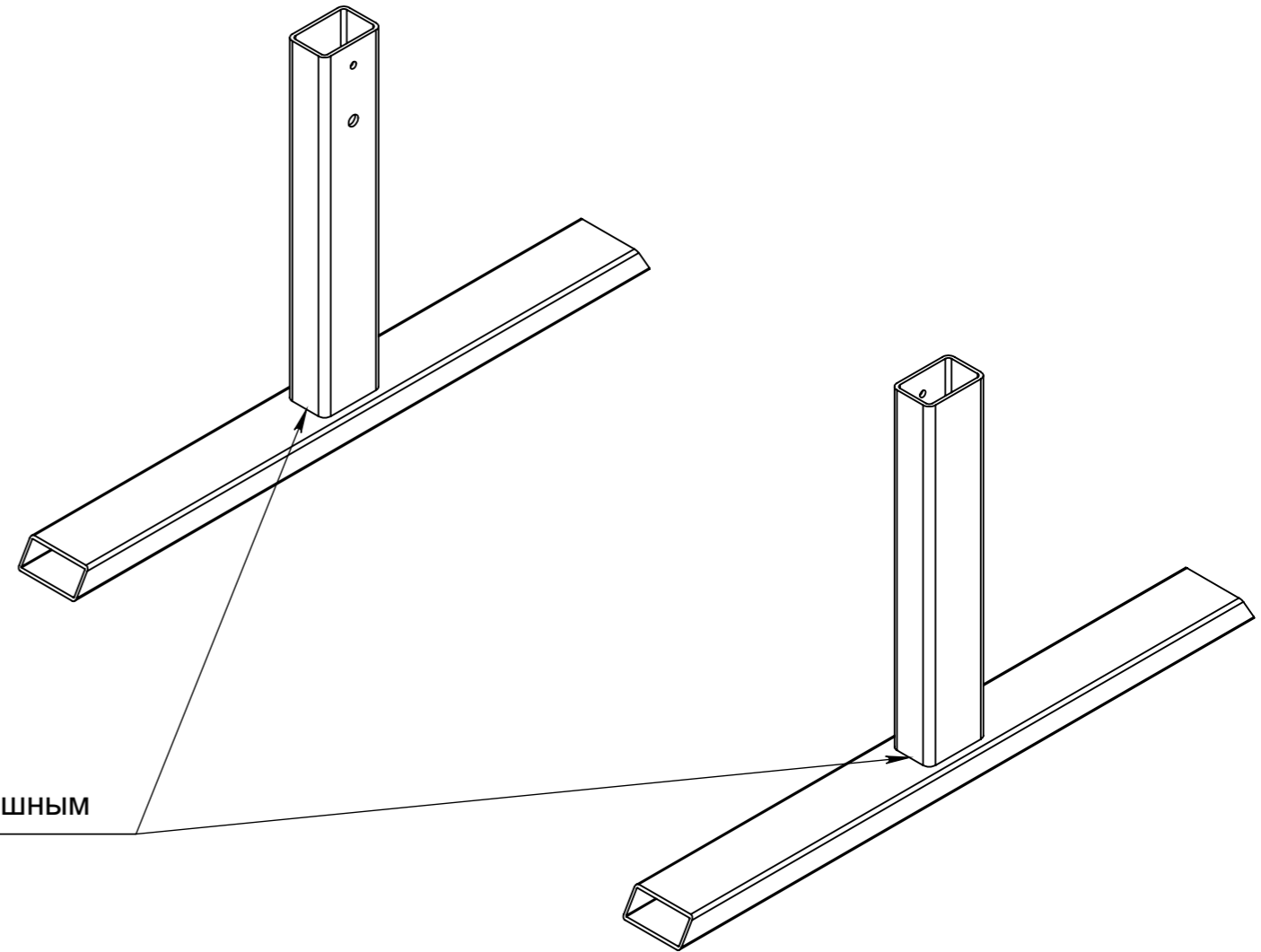

Приварить сплошным швом

Опоры столешницы

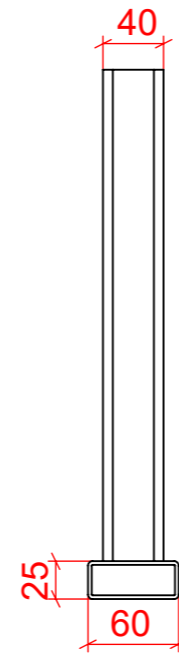
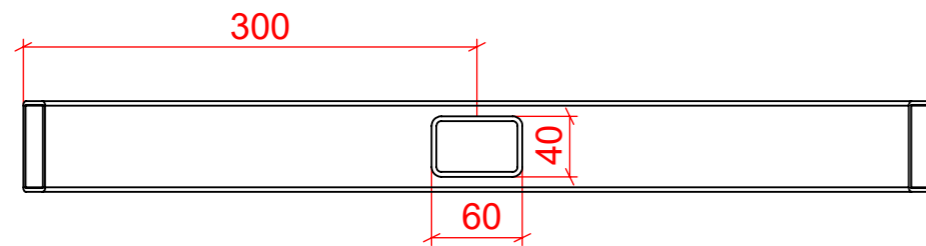
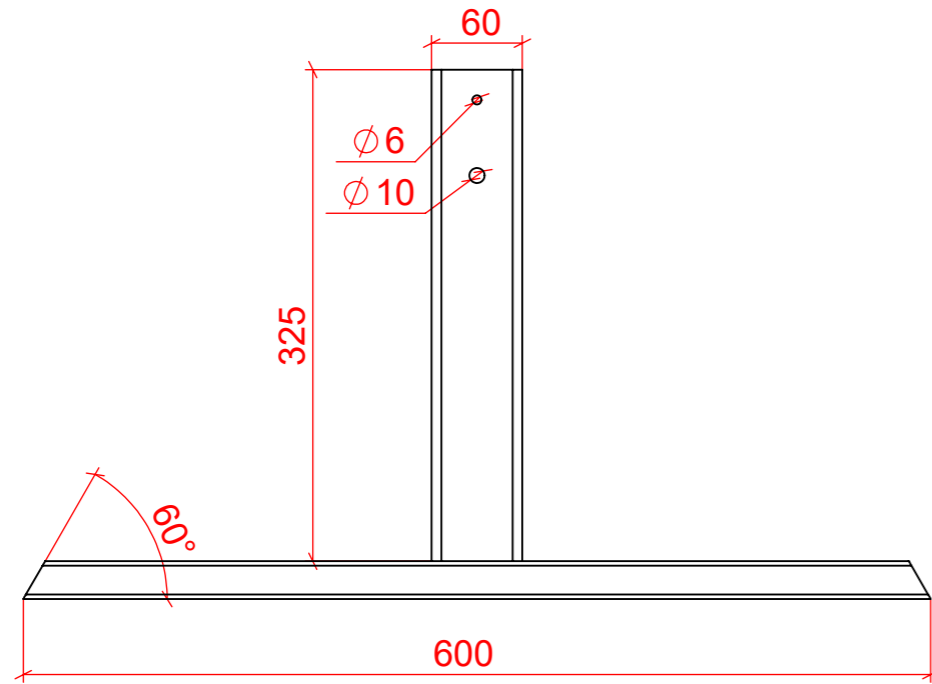
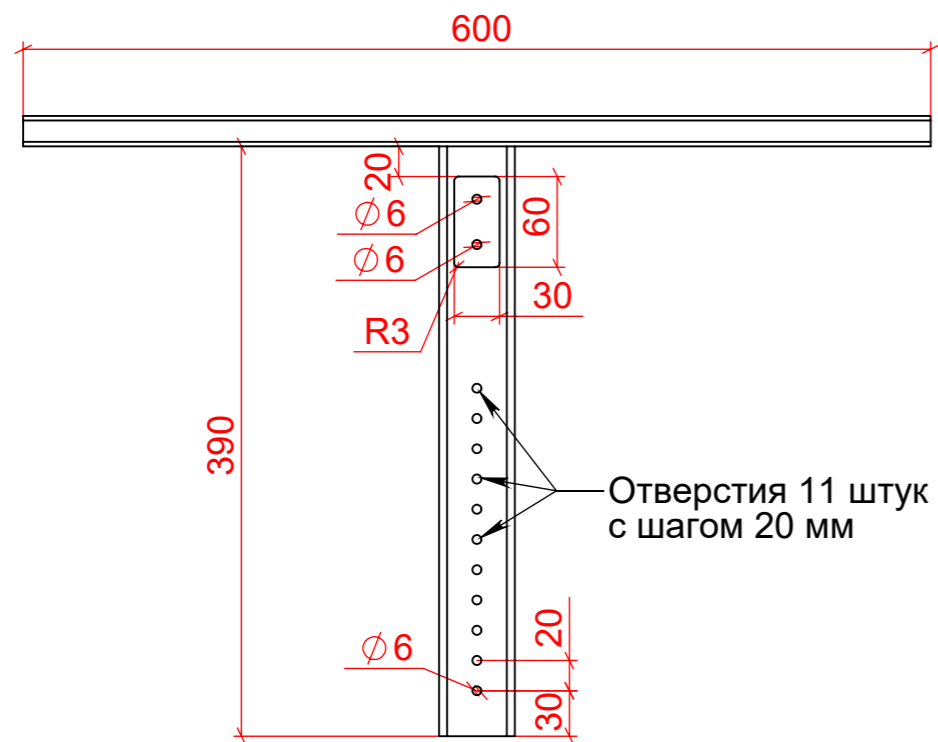

Отверстия 11 штук с шагом 20 мм

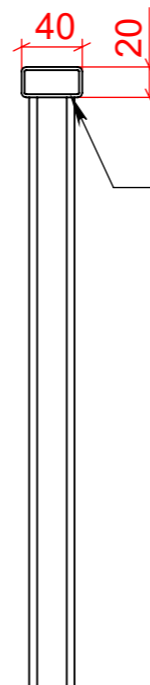
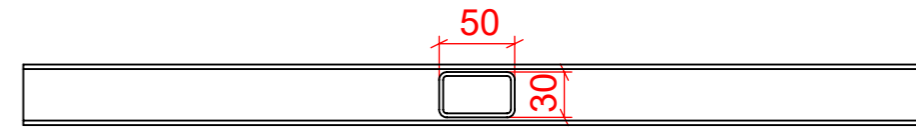

Приварить сплошным швом

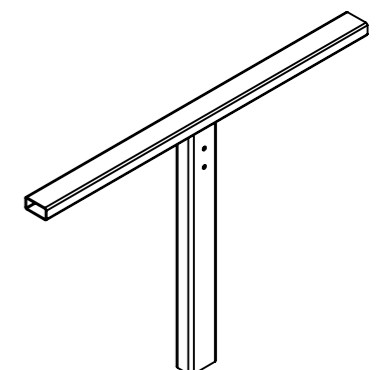
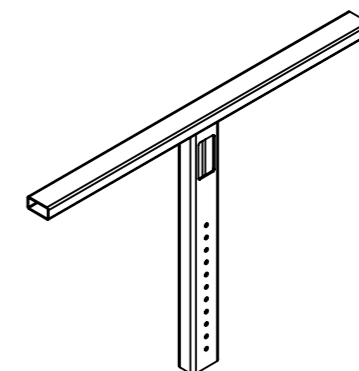
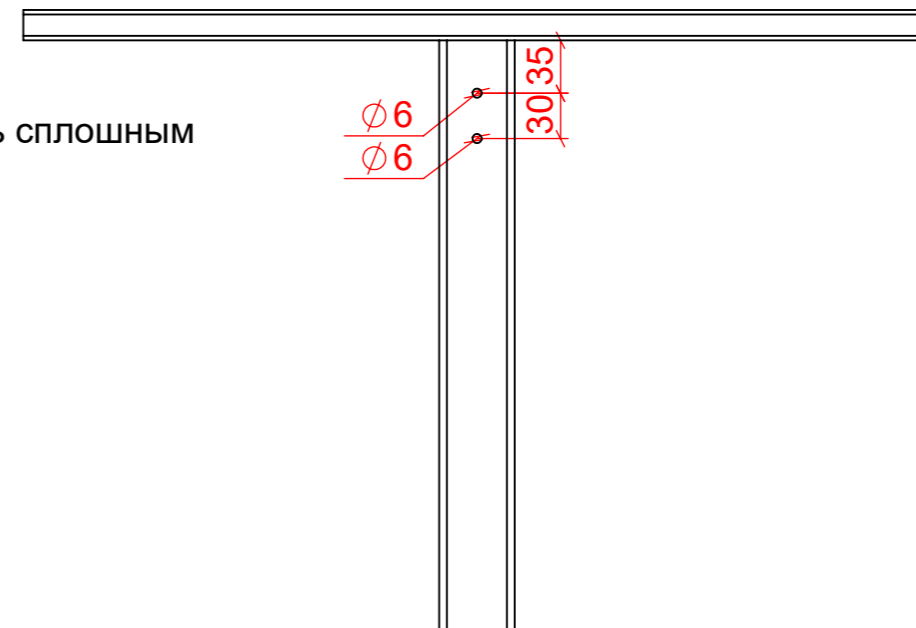

Перемычка

